

# DeJelin

Your Health Partner

USER MANUAL



NutriSoup

NS148

## Thank you for your purchase!

The Dejelin NutriSoup NS148 is the perfect partner to fill up with vitamins: velvet soups or broths, hot or cold vegetable milk, compotes or simple smoothies. Discover the 8 programs, which will make your daily life easier and provide a feast for your family.

## VEILIGHEIDSRICHTLIJNEN

Read this User Manual carefully before using the appliance and keep it carefully for later use if needed.

1. Persons (including children under 8) who are not fit to use the appliance safely, either because of their physical, sensory or mental abilities, either because of their lack of experience or knowledge, cannot use the appliance under any circumstances without surveillance or without the instructions of a responsible person.
2. Never immerse the complete appliance in water nor hold it under the tap, since it contains electrical parts and heating elements. Risk for electrical shocks!
3. Before plugging in the appliance, check if the voltage indicated on the appliance corresponds with the mains voltage of your home.
4. Don't use the appliance if the plug, the electrical cord or the appliance are damaged.
5. If the electrical cord is damaged, in order to avoid any danger, it has to be replaced by the technical department, after sales service or equal of the manufacturer.
6. Never let the cord hang over sharp edges.
7. Children should be supervised, never let them play with the appliance.
8. When the appliance is working, or cooling, the appliance and the electrical cord should be held out of reach of children under the age of 8.
9. Make sure the electrical cord doesn't come into contact with hot surfaces.

## VEILIGHEIDSRICHTLIJNEN

10. Never plug in the appliance, or touch the control panel with wet hands.
11. The appliance always should be plugged into an earthed wall socket, make sure the appliance is always plugged in correctly.
12. Never connect the appliance to an external timer, this could be dangerous.
13. Never place the appliance against a wall or any other appliance. Always keep minimum 10 cm free on all sides of the appliance. Don't put any objects on the appliance.
14. Never use the appliance differently than prescribed in this manual.
15. Never let the appliance work unsupervised.
16. Place the appliance on a dry surface.
17. During use of the appliance, the surface under the appliance can become very hot.
18. The jug of the appliance can become very hot during use. Don't touch it with your hands but use the handle.
19. Be careful when removing the lid after a "hot program", since hot steam could come out of the steam outlet or out of the jug itself.
20. Don't remove the lid when the knives are still turning.
21. Carefully handle the lid with the sharp knives during assembly or cleaning.
22. If the appliance is used wrongly, or for professional purposes or semi-professional purposes, or if it is not used according the instructions in the user manual, the warranty is void and we would have the right to refuse all responsibility regarding possible damage.
23. Repairs may only be done by a recognized repair or service centre. Never repair the appliance yourself, this would void the warranty.
24. After use, always pull the plug from the socket.
25. Always let the appliance cool before cleaning and maintenance.

# PARTS

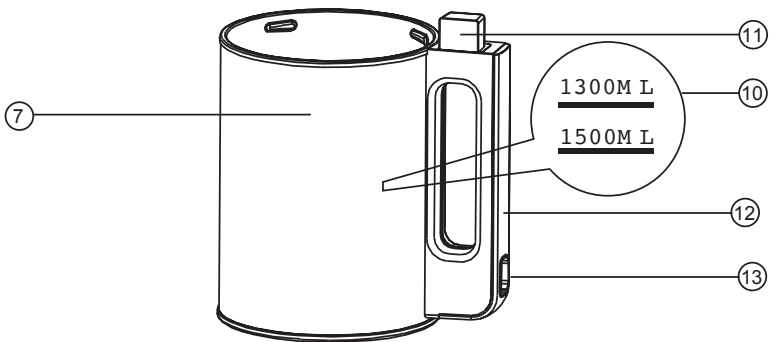
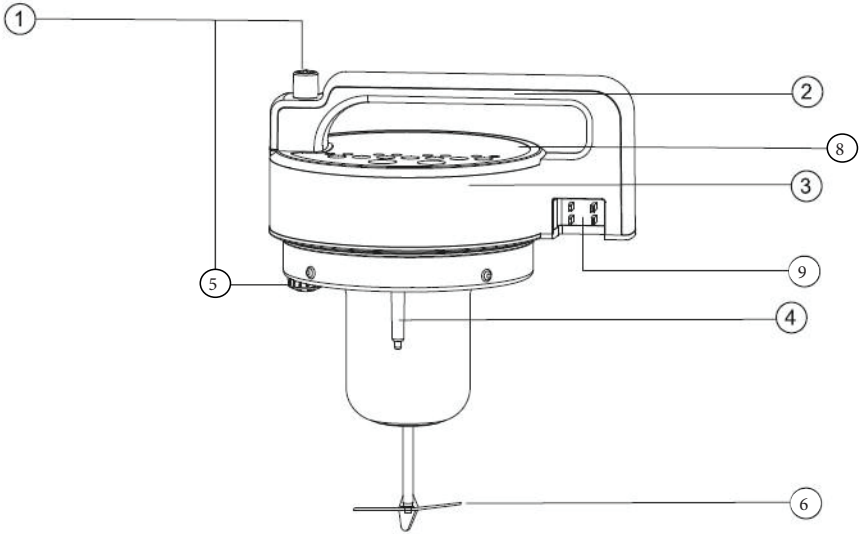

# PARTS

1. Steam valve
2. Lid and motor block handle
3. Lid and motor block
4. Anti-overflow sensor
5. Steam outlet
6. Knife
7. Jug
8. Control panel
9. Power connector lid and motor block
10. Quantity indicator
11. Power connector lid and motor block
12. Jug handle
13. Power supply

## ACCESSORIES

- Soaking bowl
- Fine mesh sieve
- Cleaning brush
- Cleaning sponge
- Electrical cord

# PUTTING INTO SERVICE & USE

## BEFORE FIRST USE

- Remove all packaging, stickers and labels
- Clean all accessories with hot soapy water and a soft sponge, as well as the inside and the outside of the appliance.

**Warning** : nor the jug, nor the lid motor block are dishwasher proof.

## INSTRUCTIONS FOR USE

1. Make sure the NutriSoup is unplugged
2. Remove the lid holding the jug handle with the right hand and the lid handle with the left hand and then turn the lid counter clockwise.

*Never place the soaking bowl in the jug when the appliance is working.*

### WARNING !

Don't touch the knife as it is very sharp. The knife could scratch your working area. Therefore, put it on a plate or on every other protected surface.

3. Cut the ingredients in cubes of maximum 2 cm. With the 'Broth' Program, you may use larger pieces, but be careful with harder vegetables (such as carrots) because they might not cook correctly.

*Don't insert frozen ingredients in the NutriSoup. Thaw them in advance*

4. Insert all the ingredients and the liquid (water, milk, broth...) in the jug. The NutriSoup only functions when filled with liquid between the MIN mark (1,3L) and the MAX mark (1,5L). If you exceed the MAX mark, the anti-overflow sensor will activate and prevent the NutriSoup to

## PUTTING INTO SERVICE & USE

function.

5. Put the lid correctly back into place and make sure it is tightly closed.
6. Connect the electrical cord to the power connector and plug in the appliance. The NutriSoup will make a sound.
7. Repeatedly press the MENU button to select the desired program.
8. Press START to start the program.
9. When the program is finished, the NutriSoup will once more make sound. Carefully remove the head and make sure to put the knife on a protected surface.
10. Pour your soup into a bowl. If you want your soup to remain hot, just put the head back on. The isothermal jug will keep your soup hot.









### NOTES!

- Meat should be precooked before putting it in the NutriSoup.
- The NutriSoup doesn't allow to deep fry or to cook food.

# PUTTING INTO SERVICE & USE

## PROGRAMS

All programs are preset, and it is not possible to change them.

PROGRAM	PREPARATION	T°	TIME
 Smooth	Velvet soup	100°C	21 min
 Mixed	Mixed soup	100°C	30 min
 Broth	Broth, ragout	100°C	38 min
 Compote	Compote, coulis	100°C	16 min
 Smoothie	Smoothie, vegetable milk	0°C	3,5 min
 Pulse*	Manual mixing	0°C	-
 Porridge	Porridge, baby food	100°C	35 min
 Auto cleaning		0°C	3,5 min

\* The Pulse program only functions if you selected it in advance with the MENU button. Once selected, press the START button for a few seconds to obtain the desired texture. We don't recommend to mix for more than 30 seconds at once. The PULSE function works without heat. Therefore, you can use it to mix preparations such as milk-shakes or smoothies.

WARNING:

Don't repeat hot programs more than 5 successive times.



# PUTTING INTO SERVICE & USE

## MAINTENANCE

After use, rinse the interior of the jug with hot water to remove all soup residue. You can also fill the jug (up to the MAX mark) with hot water and use the PULSE function for a few seconds to make cleaning easier. Then, use the provided sponge, dipped in hot soapy water, to clean the inside of the jug, rinse with hot water and let dry. The knife and the plunger can be cleaned with the brush (also included) and hot water. Thoroughly dry the appliance after use. Dry the inside with a soft, dry cloth.

### WARNING:

- The NutriSoup is not dishwasher proof
- Don't immerse the head, the jug, the electrical cord nor the plug in water or any other liquid. This would damage the appliance.
- The power connector between the lid and the jug cannot get wet.

## ENVIRONMENT - NORM 2002/96/CE

In order to protect our environment and your health, disposal at the end of the lifetime of electric appliances must be treated under certain rules and this requires involvement of everyone, supplier or user. Therefore, your appliance cannot in any way be disposed in a public waste bin or with normal domestic waste, as indicated by the symbol on the rating plate.

## PUTTING INTO SERVICE & USE

When disposing of the appliance, it is your responsibility to bring the appliance to an official collection centre for recycling of electric and electronic appliances.

For more information on the collection centres for recycling of appliances at the end of their lifetime, please contact the local authorities in your area, the household waste disposal service provider or the store where you bought your appliance.



### ELECTRICAL CORD

Carefully check the electrical cord before each use. If it is damaged, do not use the appliance. The electrical cord can only be replaced by Dalcq S.A., her after sales service or a capable and authorized person in order to avoid any danger for the user. The electrical cord used is a HO5VV-F 3 G 0,75 mm<sup>2</sup>. These appliances comply to the 2006/95/ CE, 2004/108/CE, DEEE 2002/96/CE, rohs 2002/95/CE norms and the 1935/2004 regulation of the European Parliament on materials and articles intended to come into contact with food.

## WARRANTY

Dalcq S.A. provides a special warranty on all parts of the appliance subject to conditions below. The legal regulations about warranty, as well as the rights resulting from the legislation about responsibility of the defective products remain unaffected. Possible right to reimbursement of the buyer in case of defaults remain valid, if the conditions below are met.

# WARRANTY

## 1. Period of the warranty

The warranty applies to all parts of the appliance and starts from the date of purchase (date of invoice) of the appliance and has a duration of 2 years when used privately

## 2. Object of the warranty

Dalcq S.A. covers the material, construction and manufacturing defaults, provided the default was present at delivery and that the appliance was correctly operated by the buyer. The warranty covers free repair, or exchange of one or more defective components, or the exchange of the appliance for another appliance of the same value. It is up to Dalcq S.A. to decide which measure to undertake.

## 3. Warranty case

When breakdown/default, you must immediately advise:

1. The store where you bought the appliance.
2. The after sales service (written or via email) that the appliance will be returned, to provide an extended description of the problem with pictures.

## 4. Packaging

It is recommended to use the original packaging to return the appliance. If you use a different packaging, make sure it provides enough protection for typical transport risks and that it offers sufficient protection. A simple cardboard box filled with paper is not sufficient. Dalcq S.A. cannot be held responsible for damage resulting from insufficient packaging. The warranty then expires. The after sales service will inform you of the return procedure as well as of the costs this implies.

# WARRANTY

## 5. Cleaning

If you don't clean the parts or the appliance before returning it, Dalcq S.A. will invoice a cleaning set rate. It is the responsibility of the buyer to prove the real costs of cleaning are inferior to the invoiced set rate.

## 6. Withdrawal of the right to warranty

The right to warranty is withdrawn by:

- Incorrect use, treatment and storage. (For example, defaults caused by humidity, high temperatures)
- Repairs, repair attempts, modifications of any kind and use of non-original parts, etc. which were not executed by Dalcq S.A. or by an authorized company.
- Insufficient packaging and bad transport.
- Inappropriate mechanical influences on the appliance or on the parts of the appliance.
- Defaults that are not caused by the finishing or production of the appliance, such as fall, collision, damage, fire, earthquake, damage by flood, lightning, etc.
- Use other than household use, especially in a commercial environment.
- The costs incurred by Dalcq S.A. because of the returning of the appliance by the buyer, without warranty or right to restitution will be for the buyer.

## 7. After Sales Service

### Dalcq N.V.

Rue du Hainaut 86  
6180 Courcelles  
Belgium  
support@dalcq.com